

*The World Leader in External Fuel Tanks and Pylons, Aerial Refueling Systems,
Special Purpose Pods, and Pneumatic Suspension and Release Equipment*

AERIAL REFUELING BUDDY-BUDDY STORE

MODEL 28-300-48116

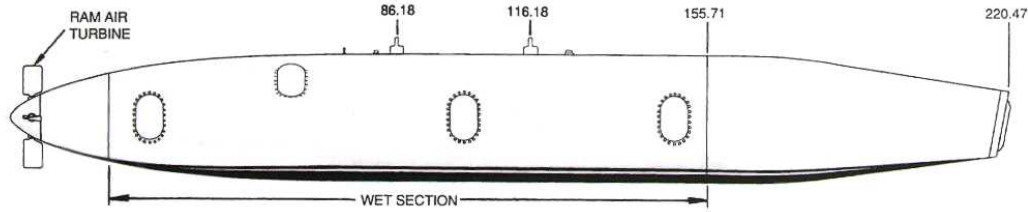

Fuel: JP-4, JP-5, JP-8
 Fuel Transfer Rate: 200 GPM (757 L/min)
 Fuel Pressure at Coupling: 65 psig (448 kPa)
 Refueling Coupling: MA-3
 Electrical Power Requirements: 28 V dc
 Hydraulic Fluid: MIL-H-83282
 Operating Pressure: 3000 psi (20,684 kPa)
 Power Source: Ram Air Turbine

FLIGHT ENVELOPE

Operating Altitude Range: Sea Level to 40,000 ft (12,192 m)
 Operating Temperature Range: -65° to +160°F (-54° to +71°C)
 Operating Air Speed: 200-325 KIAS
 Emergency Provisions: Hose Guillotine, Jettison and Sealing;
 Pod Jettison

POD SPECIFICATIONS

Diameter: 28 in (71cm)
 Length Overall: 220.47 inches (559.99 cm)
 Mounting: Fuselage Centerline,
 Crutchless Suspension
 Fuel Capacity: 300 U.S. Gallons (1136 Liters)
 Empty Weight: 725 lb (329 kg)
 National Stock Numbers: 1560-01-146-9551
 1560-01-146-9552
 1560-01-146-9553
 Technical Manual: (German Air Force Publications)
 6A99-2BXC 1-2, 6A99-2BXC 1-3
 6A99-2XC 1-4
 Aircraft Applications: Panavia Tornado



*German Air Force Tornado
 Refueling Italian Air Force Tornado
 with Buddy-Buddy Store*

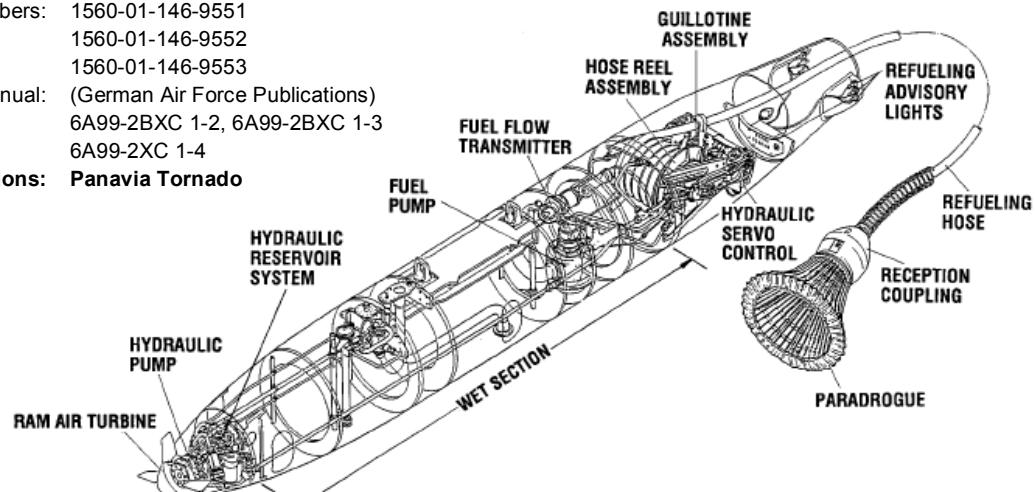

SARGENT FLETCHER

COBHAM

9400 Flair Drive, El Monte, California 91731 • Phone: (626) 402-2343 • FAX: (626) 579-9183
 Visit our web site at: www.sargentfletcher.com • email: Business.Development@sargentfletcher.com

SARGENT FLETCHER INC.